

Warm-UP: INQUIRY SKILL FOCUS Assessment

Skills Test B: Measure and Calculate (*continued*)

Questions 13–14: Use the diagram below to answer each question. Write your answer on the line at the left.

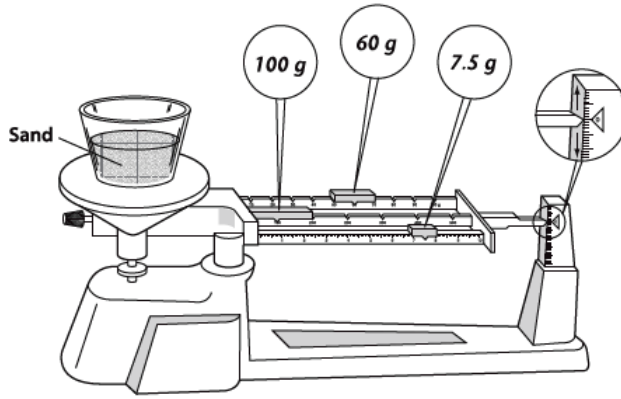

- _____ 13. What is the mass of the container and the sand together?
 _____ 14. If the mass of the container is 14.5 grams, what is the mass of the sand?

Questions 15–19: The diagram below shows five Celsius thermometers. Use these diagrams to answer each question. Write your answer on the line at the left.

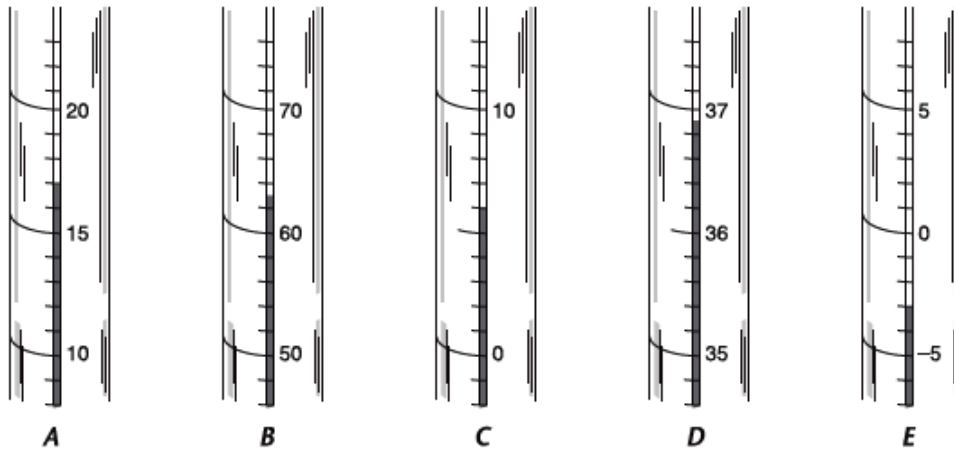

- _____ 15. What is the temperature on Thermometer *A*?
 _____ 16. What is the temperature on Thermometer *B*?
 _____ 17. What is the temperature on Thermometer *C*?
 _____ 18. What is the temperature on Thermometer *D*?
 _____ 19. What is the temperature on Thermometer *E*?

Skills Test B: Measure and Calculate (*continued*)

Questions 20–21: The diagram below shows a Celsius thermometer on different days. Use the diagram to answer each question. Write your answer on the line at the left.

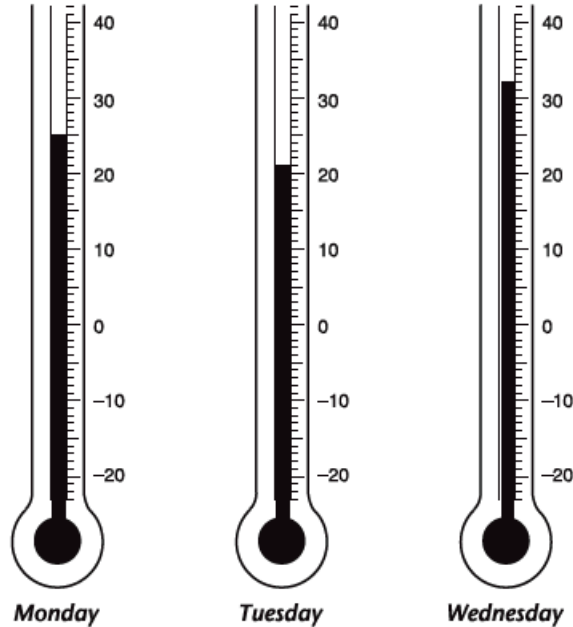

_____ 20. What was the decrease in temperature from Monday to Tuesday?

_____ 21. What was the increase in temperature from Tuesday to Wednesday?

Questions 22–25: Convert between the following SI units. Show all your work. Write your answer on the line at the left.

_____ 22. 34.0 kilograms = _____?_____ grams

_____ 23. 30.0 meters = _____?_____ centimeters

_____ 24. 250 milliliters = _____?_____ liters

_____ 25. 4,500 meters = _____?_____ kilometer